



# Max 2

GoPro  
■■■■

## Join the GoPro Movement



@GoPro



@GoPro



@GoPro



facebook.com/GoPro



@GoPro



pinterest.com/GoPro

## Contents

---

Meet MAX2	6
Getting Started	8
Powering On + Recording	14
Using the Touch Screen	16
360 + Single Lens Mode	18
Invisible Mounting + Tips for 360 Capture	19
Capture Modes + Presets	20
Adjusting Capture Settings + Presets	23
Using Shortcuts	30
Protune	32
Using Voice Control	35
Looping Video	38
HiLight Tags	39
Exposure Control	40
Screen Orientation	44
Using Your GoPro Around Water	45
Timecode Sync	46
Playing Back Your Media	47
Pairing to the Quik App + Other Devices	51
Automatic Highlight Videos	52
360 Editing With the Quik App	53

## Contents

---

Using the Dashboard	54
Saving + Deleting Your Media	55
Setting Your Preferences	59
Mounting Your GoPro	66
Replacing the Lenses	72
Removing the Door	73
Maintenance	75
Battery Information	76
Camera Alerts	79
Resetting Your Camera	80
Troubleshooting	82
Customer Support	83
Trademarks	83
Regulatory Information	83

## Meet MAX2

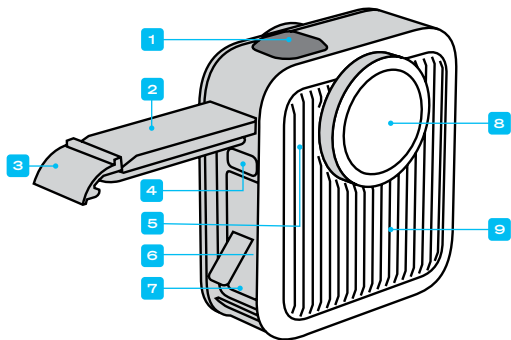

1. Shutter Button 
2. Door
3. Door Latch
4. USB-C Port
5. Status Light
6. microSD™ Card Slot
7. Battery

8. Replaceable Lens
9. Heat Sink  
(WARNING: To help prevent overheating, the heat sink may get extremely hot when camera is in use.)

## Meet MAX2

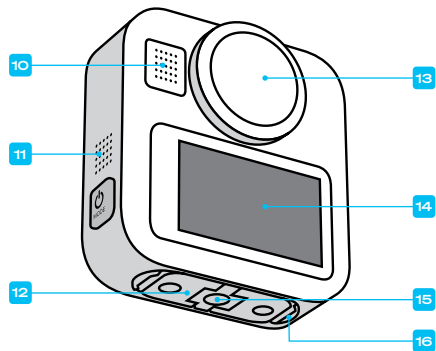

10. Microphone
11. Speaker
12. Folding Fingers
13. Replaceable Lens
14. Touch Screen

15. 1/4-20 Mounting Threads
16. Magnetic Latch Mount Connection Point  
(Magnetic Latch Mount sold separately.)

## Getting Started

---

### SD CARDS

You'll need a microSD card (sold separately) to save your videos and photos. Use a brand-name card that fits these requirements:

- microSD, microSDHC™, or microSDXC™
- Class A2 and V30 speed class rating or higher
- Capacity up to 1TB

For a list of recommended microSD cards, visit [gopro.com/microsdcards](https://gopro.com/microsdcards).

Be sure your hands are clean and dry before handling your SD card. Check the manufacturer's guidelines to see your card's acceptable temperature range and other important information.

*Heads Up:* SD cards can degrade over time and affect your camera's ability to save your media. Try swapping out an older card for a new one if you're having any problems.

---

**PRO TIP:** Keep your SD card in good condition by reformatting it regularly. This will erase all of your media, so be sure to save it first.

1. Swipe down on the rear screen to access the Dashboard.
2. Swipe left and tap Preferences > Reset > Format SD Card.

## Getting Started

---

### RECHARGEABLE BATTERY

For maximum performance, be sure to use the battery that came with your camera or the Enduro for MAX2 replacement battery.

---

**PRO TIP:** There's an easy way to check your battery's status and make sure you're using the right one.

1. Swipe down on the rear screen to access the Dashboard.
2. Swipe left and tap Preferences > About > Battery Info.



**WARNING:** Although non-GoPro batteries may fit in your MAX2, they will limit your camera's performance. Use of non-GoPro batteries will void your warranty and may cause fire, electric shock, or other safety risks.

---

For additional important information on battery safety and use, see Battery Information ([page 76](#)).

## Getting Started

---

### SD CARD + BATTERY SETUP

1. Unlock the door latch and flip the door open.

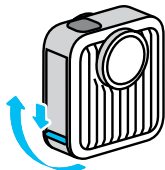

2. With your camera off and battery removed, insert the SD card into the card slot with the label facing the battery compartment.

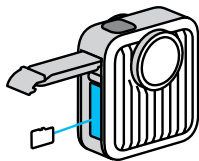

You can eject the card by pressing it into the slot with your fingernail.

## Getting Started

---

3. Insert the battery.

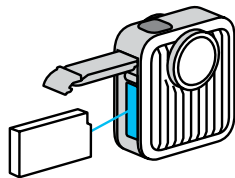

4. Connect your camera to a USB charger or computer using the included USB-C cable.

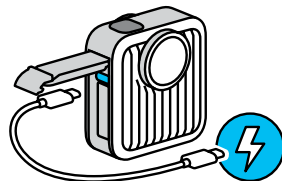

It will take about 1.5 hours to fully charge the battery using a 15W (3A) charger. The camera status light will turn off when it's done.

## Getting Started

---

5. Unplug the cable and shut the door when charging is complete. Be sure the door latch is closed and locked before using your camera.

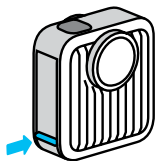

**NOTE:** Your camera's door is removable. Be sure that the door is securely locked and sealed after closing.

## Getting Started

---

### UPDATING YOUR CAMERA

You must update your camera before you can use it.

#### Updating With the GoPro Quik App

1. Download the app to your phone from the Apple® App Store® or Google Play™.
2. Make sure you have Internet access, then turn on your GoPro by pressing the Mode button .
3. Follow the app's on-screen instructions to complete the update.

#### Updating Manually

1. Visit [gopro.com/update](https://gopro.com/update).
2. Choose MAX2 from the list of cameras.
3. Select Update Your Camera Manually and follow the instructions.

---

**PRO TIP:** The app will check for the latest camera software every time it connects to your GoPro. This helps ensure that you'll always have the latest features and best performance from your GoPro. If new software is available, the app will tell you how to install it.

---



**WARNING:** Do not remove your battery or SD card from your GoPro while the update is in progress. Removing your battery or SD card during an update may permanently damage your GoPro.

---

## Powering On + Recording

---

### POWERING ON

Press the Mode button  to turn on your camera.

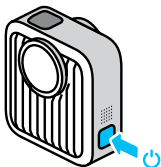

### POWERING OFF

Press and hold the Mode button  for 3 seconds to turn it off.

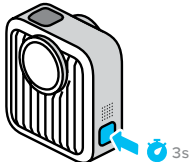

**WARNING:** Use caution when using your GoPro and its mounts and accessories. Always be aware of your surroundings to avoid injuring yourself and others.

Be sure to follow all local laws including all privacy laws, which may restrict recording in certain areas.

---

## Powering On + Recording

---

### RECORDING WITH QUIKCAPTURE WHEN YOUR CAMERA IS OFF

QuikCapture is the fastest way to power on your GoPro and get the shot.

1. With your camera off, press the Shutter button .



2. Press the Shutter button  again to stop recording and turn off your camera.

*Heads Up:* QuikCapture is on by default, but you can turn it off.

1. Swipe down on the rear screen to access the Dashboard.
2. Tap .

**PRO TIP:** Since it only turns your camera on when it's recording, QuikCapture is a great way to maximize battery life.

### RECORDING WHEN YOUR GOPRO IS ON

With your GoPro on, press the Shutter button  to get the shot with the mode you selected. Press the button again to stop recording (Video and Time Lapse only).

## Using the Touch Screen

---

### THE TOUCH SCREEN

The rear touch screen gives you access to your camera's capture settings and status.

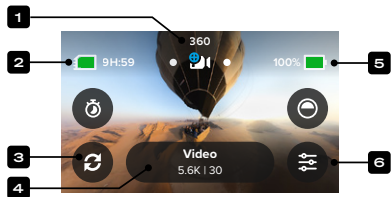

1. Current Mode (⊕ indicates that you're in 360 mode)
2. Recording Time/Photos Remaining
3. Customizable On-Screen Shortcuts
4. Capture Settings/Center Button (tap to change presets or tap and hold to access settings for the current mode)
5. Battery Status
6. Settings Shortcut (tap to access and change settings for the current mode)

*Heads Up:* The capture settings are not available when you turn your GoPro to take portrait shots. Be sure to choose the settings you want before rotating your camera.

---

**PRO TIP:** Press the Mode button  to quickly jump back to this screen from almost anywhere.

## Using the Touch Screen

---

### USING THE TOUCH SCREEN



**Tap**  
Select an item to turn it on or off.

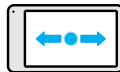

**Swipe Left or Right**  
Switch between capture modes.

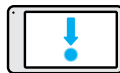

**Swipe Down from the Edge of the Screen**  
Open the Dashboard when your camera is in landscape orientation.



**Swipe Up from the Edge of the Screen**  
See the last photo or video you captured and access the Media Gallery.



**Press and Hold the Capture Screen**  
Turn on and adjust Exposure Control.

---

**PRO TIP:** You can hide your camera's status information and icons on both the front and rear screen by tapping the rear screen. Tap the screen again or press a button to bring it all back.

## 360 + Single Lens Mode

---

MAX2 captures spherical footage in 360 mode or traditional videos and photos in Single Lens mode.

### 360 MODE

Use 360 mode to capture everything around you. View and share it as 360 content or use the GoPro Quik app to Reframe it as traditional videos and photos. 360 mode records using both lenses, but you can tap  to choose the lens view that will be shown on the screen.

### SINGLE LENS MODE

Single Lens mode lets you shoot traditional videos and photos with either the front (non-touch screen side) or back lens (touch screen side). Simply tap  to choose the lens you want to use.

---

**PRO TIP:** Choose Single Lens mode and the back lens to frame and capture perfect selfies.

### SWITCHING BETWEEN 360 + SINGLE LENS MODE

1. Swipe down on the rear screen to access the Dashboard.
2. Tap Camera Mode  to toggle between 360 and Single Lens mode.

## Invisible Mounting + Tips for 360 Capture

---

### INVISIBLE 360 POLE SHOTS

Capture amazing pole-mounted footage where the pole vanishes out of the shot. Just attach your GoPro to a compatible extension pole using the 1/4-20 mounting threads on the bottom of your camera. The pole will be automatically edited out of your 360 footage.

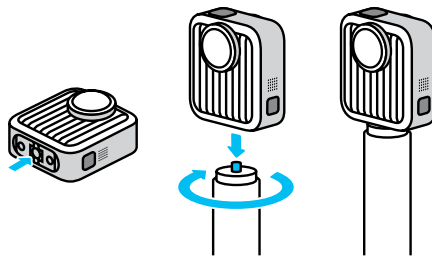

*Heads Up:* The pole must be at least 14" (36cm) long and extend straight down from the bottom of your camera.

### TIPS FOR CAPTURING 360 CONTENT

- Use voice commands, a GoPro remote, or the GoPro Quik app to start recording remotely so you don't have to move your hand out of the way after pressing the Shutter button.
- Extension pole mounting is recommended, but if you're going to take a handheld shot, hold MAX2 near its base to minimize how much of your hand gets into the shot.

## Capture Modes + Presets

---

### CAPTURE MODES + PRESETS

Your GoPro has a variety of capture modes for video, photo, and time lapse shots. Using the rear touch screen, swipe left or right to the one you want.

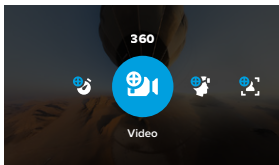

Each capture mode has presets that make it easy to switch back and forth between the best mode and settings for your shot.

Mode	Preset	Description
Video	Video	Records in resolutions up to 8K in 360 mode and 4K in Single Lens mode.  <i>Heads Up:</i> 8K support on phones varies by device. You may experience issues with playback, editing, and sharing. Try recording at a lower resolution if you have any problems. Visit <a href="https://gopro.com/support">gopro.com/support</a> for more information on phone compatibility.
POV	POV	Plays back 360 footage from your point of view.

## Capture Modes + Presets

---

Mode	Preset	Description
Selfie	Selfie	Records 360 footage that keeps the focus on you during playback.
Photo	Photo	Captures 360 or Single Lens photos with SuperPhoto image processing.
	Burst	Shoots up to 30 photos in 3 seconds in 360 mode.
	Night Photo	Automatically adjusts shutter speed in 360 mode for low-light shots.
Time Lapse	TimeWarp	Captures stabilized 360 or Single Lens time lapse footage while you're on the move.
	Star Trails	Mount MAX2 to a stationary object to capture trails of light across the sky in 360 mode.
	Light Painting	Mount MAX2 to a stationary object, grab a flashlight, glow stick, or other light source, and get creative in 360 mode.
	Vehicle Lights	Mount MAX2 to a stationary object to create stunning light trail footage from moving vehicles in 360 mode.
	Time Lapse	Use to capture 360 or Single Lens time lapse video and photos when your camera is still.
	Night Lapse	Use to capture 360 or Single Lens time lapse video and photos in low-light environments.

## Capture Modes + Presets

### CHANGING PRESETS

You can swap presets after choosing your capture mode.

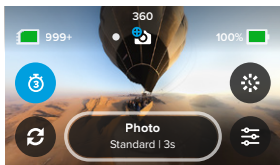

1. From the capture screen, tap the center button

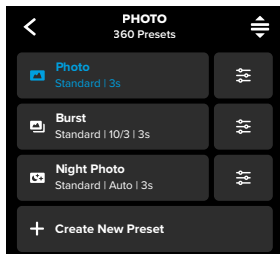



Tap the preset that you want from the list. All of the preset's settings will be locked into your camera and ready to go.

## Adjusting Capture Settings + Presets

### ADJUSTING SETTINGS

The capture settings can be adjusted to help you get the perfect shot. Each capture mode and preset has its own unique settings. You can access them from the capture screen.

1. Tap the settings shortcut .
2. Scroll through the settings and tap the one you want to adjust.
3. Tap  to save your changes.



You can also tap  or scroll down to "save as" to save the changes as a new preset.

*Heads Up:* You can't delete the preloaded presets, but you can customize them any way you want. You can also create your own custom presets.



**PRO TIP:** You can also change your camera settings using the GoPro Quik app.

### RESTORING PRESETS TO THEIR ORIGINAL SETTINGS

You can restore all of a capture mode's original preset settings at any time.

1. From the presets screen, tap .
2. Tap  to reset all of the presets back to their original settings.
3. Tap Reset when prompted.

You can also restore original settings of individual presets.

1. From the capture screen, tap the center button .
2. Tap the preset that you want to restore from the list.
3. Scroll to the bottom of the settings list and tap  Restore.

## Adjusting Capture Settings + Presets

### VIDEO SETTINGS

Setting	Preset	Description
Profile	360 + Single Lens Video	Choose to record standard or Log video (8K 10-bit 360 and 10-bit Single Lens video only, LUT provided). <i>Heads Up:</i> Log video footage must be color corrected in post-production.
Resolution	360 + Single Lens Video	Choose the resolution for your video. The higher the resolution, the better the image quality.
Frame Rate	360 + Single Lens Video	A higher fps value is better for capturing fast action. You can also use high fps footage for slow motion playback.
Aspect Ratio	Single Lens Video	Choose 16:9 widescreen for playback on your phone, TV, or YouTube; 9:16 vertical for social media; or 4:3 tall aspect ratio.
Digital Lens	Single Lens Video	Choose Ultra Wide or Max HyperView, the tallest and widest field of view ever on a GoPro.
Hyper-Smooth	Single Lens Video	Choose the level of stabilization for your video—Off, On (highest level of stabilization with minimal cropping), or AutoBoost (combines maximum stabilization with variable cropping for the widest field of view possible).
Horizon Lock	Single Lens Video	Gives your videos the cinematic look of professional productions by keeping the horizon straight and level.

## Adjusting Capture Settings + Presets

### PHOTO SETTINGS

Setting	Preset	Description
Output	Single Lens Photo	Set the type of processing for your shot and how files are saved. Choose Standard, HDR, or RAW.
Digital Lens	Single Lens Photo	Choose Linear for a wide field of view without the fisheye effect, Wide for everyday shots and selfies, or Ultra Wide for extra wide and tall shots.
Horizon Lock	Single Lens Photo	Turn on to keep the horizon straight and level.
Interval	360 + Single Lens Photo	Choose how often your GoPro takes a photo—from 0.5 to 120 seconds.
Burst Rate	360 Burst Photo	Set how many photos your GoPro will take in a short burst—5 or 10 photos in 1 second, 10 or 30 photos in 3 seconds, or 30 photos in 6 seconds.
Night Shutter	360 Night Photo	Set how long your GoPro's shutter stays open for night shots. Choose longer exposures for darker shots.

## Adjusting Capture Settings + Presets

---

### TIME LAPSE SETTINGS

Setting	Preset	Description
Aspect Ratio	Single Lens TimeWarp	Choose 16:9 widescreen for playback on your phone, TV, or YouTube; 9:16 vertical for social media; or 4:3 tall aspect ratio.
	Single Lens TimeWarp, 360 Night Effects	Choose the resolution for your video. The higher the resolution, the better the image quality.
Digital Lens	Single Lens TimeWarp	Choose Linear for a wide field of view without the fisheye effect, Wide for everyday shots and selfies, or Ultra Wide for extra wide and tall shots.
Horizon Lock	Single Lens	Gives your videos the cinematic look of professional productions by keeping the horizon straight and level.
Speed	360 + Single Lens TimeWarp	Set the speed for your TimeWarp video from 2x–30x normal speed or Auto.
Interval	360 Night Effects, 360 Time Lapse	Choose how often your GoPro takes a photo or frame of video. Try shorter intervals for shorter activities or longer for activities that take place over a long period of time.

## Adjusting Capture Settings + Presets

---

Setting	Preset	Description
Night Shutter	360 Night Effects	Set how long your GoPro's shutter stays open for night shots. Choose longer exposures for darker shots.
Trail Length	360 Night Effects	Set your Night Effects trail lengths to short, long, or Max for continuous trails with no breaks.

### COMMON SETTINGS

Setting	Preset	Description
Scheduled Capture	All Modes	Set your GoPro to automatically turn itself on and start recording up to 24 hours in advance.
Duration	All Modes	Choose how long your camera records a video clip or takes photos before automatically stopping.
Timer	All Modes	Set up a timer to start recording your video 3 or 10 seconds after you press the Shutter button  .

## Adjusting Capture Settings + Presets

---

### CREATING YOUR OWN PRESETS

The perfect capture settings for a day on the slopes may not be so great when you're recording indoors. Custom presets let you set up and save settings for both shots so you can switch back and forth in no time.

1. Select the capture mode for your new preset—Video, Photo, or Time Lapse.
2. Scroll to the bottom of the list of presets and tap Create New Preset.
3. Tap the settings you'd like to use for your new preset. Tap ✓ when you're finished.
4. Choose an icon and name for your preset. You can choose from the list of names or use the in-camera keyboard to create your own. *Heads Up:* Chinese, Korean, and Japanese characters are not supported.
5. Tap ✓ to save your preset.

---





**PRO TIP:** You can also use the GoPro Quik app to give your new preset any name you want.

## Adjusting Capture Settings + Presets

---

### HIDING + REORDERING PRESETS

You can manage presets by hiding those you aren't currently using and rearranging your list.









1. From the capture screen, tap the center button .
2. From the list of presets, tap  in the upper right corner.
3. Tap  next to the preset you want to hide.
4. Tap, hold, and move the presets to reorder them any way you'd like.
5. Tap  to save your changes and return to the presets screen.

### DELETING YOUR PRESET



1. Go to your preset's settings.
2. Scroll to the bottom of the settings list and tap .

## Using Shortcuts

On-screen shortcuts give you easy access to your GoPro's capture settings. Simply tap the shortcut of the setting that you want to adjust.

Shortcut	Mode	Description
 Digital Lens	All Single Lens Modes	Tap to choose from the available digital lenses.
 Horizon Lock	Single Lens Video + Time Lapse	Gives your videos the cinematic look of professional productions by keeping the horizon straight and level.
 Timer	All Modes	Set up a timer to start recording 3 or 10 seconds after you press the Shutter button  .
 Lens Selector	All 360 Modes	Captures everything around you, but lets you choose which lens view is shown on the screen.
 Lens Selector	All Single Lens Modes	Lets you choose the lens for your shot. The view from the selected lens will be shown on the screen.
 Single Lens	360 Video Modes	Set your camera to use only one lens for the exposure when recording 360 video.
 Interval Photo	All Photo Modes	Set up your GoPro to take photos at fixed intervals while you stay focused on your favorite activities.

## Using Shortcuts

Shortcut	Mode	Description
 Trail Length	360 Night Effects	Set your Night Effects trail lengths to Short, Long, or Max for continuous trails with no breaks.
 Settings	All Modes	Takes you directly to the setting menu where you'll have access to all of the settings for the selected preset.

### SWITCHING OUT SHORTCUTS

Each mode has its own default shortcuts, but you can change them to the settings that you use most. You can even set up different shortcuts for each preset.

#### From the Capture Screen

1. From the capture screen, tap and hold the shortcut you want to switch.
2. Scroll through all of the available shortcuts on the right and choose the one you want.



#### From the Settings Screen

1. Tap  to access the settings.
2. Scroll down to Shortcuts.
3. Tap where you'd like to put your new shortcut.
4. Scroll through all of the available shortcuts and choose the one you want.

## Protune

---

Protune gives you full manual control of your GoPro's advanced settings. Each capture mode and preset has its own unique settings. You can access them from the capture screen.

1. Tap the settings shortcut .
2. Scroll down to the Protune section.
3. Tap the setting that you want to adjust.
4. Use the slider to make adjustments.
5. Tap  to save your changes.

### PROTUNE SETTINGS

Setting	Preset	Description
Bit Depth	Video	Choose 8-bit (default) for smaller file sizes, or 10-bit for 8K 360 and 4K Single Lens video for more post-production flexibility and color depth (LUT provided).
Shutter	Video + Photo	Set how long the shutter stays open in Video and Photo modes, or leave on Auto (default).
EV Comp	All	Exposure Value Compensation affects brightness. Use higher values for brighter images. The default setting is -0.5.

## Protune

---

Setting	Preset	Description
White Balance	All	Set the color temperature of your videos and photos. Choose lower values for warmer tones or leave on Auto (default).
ISO Min	All	Choose the minimum ISO (sensitivity to light and image noise). The default minimum is 100.
ISO Max	All	Set the maximum ISO (sensitivity to light and image noise). The default setting is 1600 for video and 3200 for photo.
Sharpness	All	Controls the quality of the details in your footage. Choose High, Medium (default), or Low.
Color	All	Lets you set the color profile for your videos and photos. Choose Natural (default), Vibrant, or Flat.
Wind Noise	Video + TimeWarp	Set to Auto (default) to filter out excessive wind (and water) noise when needed, On to always filter out noise, or Off when wind will not affect sound quality or when you want to be sure that you record in stereo.

## Protune

---

Setting	Preset	Description
RAW Audio	Single Lens Video	Creates a separate .wav file for your video. Set to Off (default), Low, Med, or High.
360 Audio	360 Video	Leave On (default) to simultaneously record in stereo and 360 spherical sound, or turn Off to record only in stereo.
Bit Rate	All Video	Choose Standard (default) to minimize file sizes, or High for bit rates up to 120Mbps.
Mics	Single Lens Video	Set to Match Lens (default) to prioritize audio to match the lens being used for recording, Front to prioritize audio coming from the front of the camera, Back to prioritize audio coming from behind the camera, or Stereo to record stereo using all of the microphones.
Single Lens Exposure	360 Video	Turn On to use only the lens view shown on the screen to set the exposure for your 360 video. Leave Off (default) to use both lenses.

## Using Voice Control

---

Voice Control gives you easy, hands-free control of your GoPro. It's great when you're busy with handlebars, ski poles, and more. Just tell your GoPro what you want it to do.

### TURNING VOICE CONTROL ON + OFF

1. Swipe down on the rear screen to access the Dashboard.
2. Tap  to turn Voice Control on or off.

### USING VOICE CONTROL TO RECORD

These commands let you get the shot and switch modes on the fly. You can simply say "GoPro, capture" to record in the mode your camera is set to or switch modes. For example, if you just recorded a video, you can say "GoPro, take a photo" to snap a photo without manually switching modes.

Command	Description
GoPro, capture	Starts capturing with the mode your camera is set to.
GoPro, stop capture	Stops capture in Video and Time Lapse modes. Photo and Burst modes stop on their own.
GoPro, start recording	Starts recording video.
GoPro, HiLight	Adds a HiLight Tag to your video during recording.
GoPro, stop recording	Stops recording video.

## Using Voice Control

---

Command	Description
GoPro, take a photo	Takes a single photo.
GoPro, shoot burst	Takes burst photos.
GoPro, start time lapse	Starts capturing with the last time lapse mode you used.
GoPro, stop time lapse	Stops capturing time lapse.
GoPro, turn off	Turns your camera off.

### USING VOICE CONTROL TO SWITCH MODES

Use these commands to switch capture modes on the go. Then say "GoPro, capture" or press the Shutter button  to get the shot.

Command	Description
GoPro, Video mode	Switches your camera to Video mode (does not start recording).
GoPro, Photo mode	Switches your camera to Photo mode (does not take a photo).
GoPro, Time Lapse mode	Switches your camera to Time Lapse photo mode (does not start taking time lapse photos).

**PRO TIP:** If you're recording video or time lapse, you must stop recording by pressing the Shutter button  or by saying "GoPro, stop capture" before trying a new command.

## Using Voice Control

---

### SEE A COMPLETE LIST OF COMMANDS ON YOUR CAMERA

1. Swipe down on the rear screen to access the Dashboard.
2. Swipe left and tap Preferences > Voice Control > Commands.

### CHANGING YOUR VOICE CONTROL LANGUAGE

1. Swipe down on the rear screen to access the Dashboard.
2. Swipe left and tap Preferences > Voice Control > Language.



*Heads Up:* Voice Control may be affected by wind, noise, and your distance from the camera. Keep your camera clean and wipe away any debris for the best performance.

## Looping Video

---

Looping lets you save space on your SD card by recording in a continuous loop until you've capture the moment you want. Use it when you're waiting for something to happen (like fishing) or when nothing may happen (like a dashcam).

### HERE'S HOW IT WORKS:

- If you select 5-minute intervals, only the previous 5 minutes are saved when you press the Shutter button  to stop recording.
- If you record for 5 minutes and don't press the Shutter button , your camera will loop back and record over the start of the video.



You can set your GoPro to record 1-, 3-, 5-, 10-, 20-, or 30-minute loops. It can also be set to Max, which will record until your SD card is full before looping back to record over the start of the video.

### SET UP LOOPING VIDEO

To capture looping video, you'll need to set up a new preset and choose Looping when selecting a capture mode.

## HiLight Tags

---

Mark favorite moments in your videos and photos by pressing the Mode button  during recording or playback. This adds a HiLight Tag  that makes those moments easier to find when you're watching your footage, creating a video, or looking for a certain shot.



You can also add HiLight Tags by saying "GoPro, HiLight" when Voice Control is on and by tapping  when watching your footage with the GoPro Quik app.

---

**PRO TIP:** The Quik app looks for HiLight Tags when it creates videos. This helps to ensure that favorite moments are included in your highlight videos.

## Exposure Control

---

Your GoPro scans the entire scene to choose the exposure level for your shot. Exposure Control lets you decide if only a section of the shot should be used to set the exposure.

Check out the shot preview on your touch screen. Try Exposure Control if there are sections that are too dark or too light.

### SETTING EXPOSURE CONTROL

If you're out in the snow on a sunny day, you might try locking the exposure on an object in the shot. This will help prevent your footage from being underexposed (too dark) compared to the bright snow.

1. Tap and hold anywhere on the touch screen until a set of brackets appears. The exposure will be based on area in the brackets.



---

**PRO TIP:** Tapping and holding the center of the screen will bring up the Spot Meter. This will base the exposure on the center of the screen.

## Exposure Control

---

2. You can change the exposure by dragging the brackets to any other area of the screen.

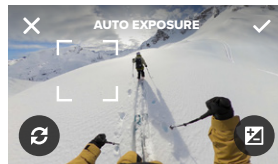

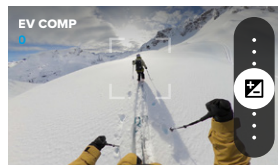

3. Brightness can be fine-tuned by tapping . This lets you adjust the Exposure Value Compensation (EV Comp).



Slide up to brighten the image. Slide down to darken it. You can adjust up to 2 stops in either direction.

## Exposure Control

---

4. Check the screen to see if the exposure looks good. Tap  inside the brackets to lock in the exposure. You can also tap  to cancel any changes.

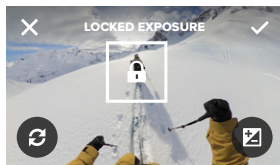

### TURNING EXPOSURE CONTROL OFF

Tapping the brackets on the capture screen will turn Exposure Control off and reset your camera to full-screen auto exposure.



*Heads Up:* If the EV Comp was adjusted during Exposure Control, it will return to its default setting when Exposure Control is turned off.

## Exposure Control

---

### SINGLE LENS EXPOSURE

In 360 mode, your camera will use the full scene (both lenses) to set the exposure. You can, however, set your camera to use only one lens. This is useful when one lens is blocked or capturing a scene where the view from one lens is significantly darker than the other.

1. In 360 mode, tap the settings shortcut  to go to the settings menu.
2. Scroll down to Protune.
3. Tap Single Lens Exposure and use the slider to turn it on.
4. Tap the Lens Selector shortcut  to choose the lens that you want to use to set the exposure. The lens view shown on the touch screen will be used. The opposite lens will not be exposed.

*Heads Up:* Once you've turned Single Lens Exposure on, you'll be able to access it quickly using the Single Lens Exposure shortcut .

## Screen Orientation

---

In Single Lens mode you can easily switch between landscape and portrait shots by rotating your camera. It can even capture photos and videos right-side up when it's mounted upside down.

The orientation is locked in when you press the Shutter button . If your camera tilts during recording, like on a mountain bike run, your footage will tilt with it. You'll capture every twist and turn.

You can lock the screen in landscape or portrait orientation. This is especially useful when you're using body and handheld mounts. That's when accidentally shooting in the wrong orientation is most likely to happen.

1. Swipe down on the rear screen to access the Dashboard.
2. Turn your camera to the orientation you want.
3. Tap  on the Dashboard.



The screen is now locked and will match the orientation of your camera.

## Using Your GoPro Around Water

---

Though MAX2 is not suitable for underwater use due to image distortion, it is waterproof to 16ft (5m) with the door locked. You won't need an additional housing to capture surf footage or any other shots on the water.

The touch screen was designed to work when wet, but you may need to wipe it off if it has trouble sensing your commands. You can also use the camera's buttons to navigate the menus if the screen isn't working.

1. With the camera on, you can press the Mode button  to switch modes.
2. Hold down the Mode button and press the Shutter button . A menu will appear on the front screen.
3. Press the Mode button to scroll through the presets.
4. Use the Shutter button to select a preset.

*Heads Up:* The Dashboard and Media Gallery are not available when navigating with the buttons.

---

**PRO TIP:** Use the Screen Lock feature (available on the Dashboard) to prevent accidental screen taps and possible changes to your settings caused by water droplets.

## Timecode Sync

---

Timecode sync is available through the GoPro Quik app. This lets you sync the date and time on multiple MAX2, HERO13 Black, and HERO12 Black cameras for easier and more precise editing.

1. Add your MAX2 to the GoPro Quik app.
2. Tap  on the app's MAX2 control screen.
3. Tap Sync Timecode. This will bring up a QR code.
4. Scan the QR with any MAX2 using any mode or preset.

Your GoPro will let you know if the sync was successful.

*Heads Up:* After adding MAX2 to the app, you can access timecode sync through the app's MAX2 control screen at any time. You don't have to connect your camera.







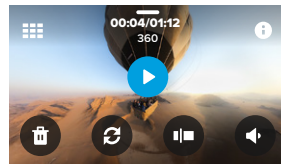

## Playing Back Your Media

---

Swipe up to see the last video, photo, or burst you took. Swipe left and right to flip through the other files on your SD card.





The Media Gallery includes the following playback options:

-  Pause playback
-  Resume playback
-  See all of the media on your SD card
-  See the mode and all of the settings used to capture the shot
-  Delete the file from your SD card
-  Play back in slow motion or normal speed
-  Use a slider to scan through your videos, bursts, and time lapse photos
-  Switch between lens views when watching 360 content

## Playing Back Your Media

---

-  Add/remove HiLight Tag
-  Turn audio on or off during playback
-  Go to the previous or next photo in a burst or group of continuous photos

---

**PRO TIP:** Some playback options are not available when you're holding your camera in portrait orientation. Make adjustments to those settings in landscape orientation before rotating your camera.

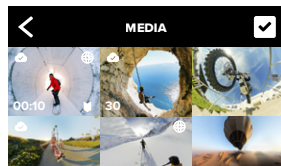

## Playing Back Your Media

---



### USING GALLERY VIEW

Gallery view gives you quick access to all of the videos and photos stored on your SD card.

1. From the playback screen, tap .
2. Swipe up to scroll through your media.
3. Tap a video or photo to see it in full-screen view.
4. Tap  to select files.
5. Tap  to go back to the playback screen.

*Heads Up:* Gallery view is not available when you're holding your camera in portrait orientation. Also, the more content you have on your SD card, the longer it will take to load.



---

**PRO TIP:** All 360 content is tagged with the 360  icon.

## Playing Back Your Media

---

### DELETING MULTIPLE FILES

1. Tap .
2. Tap all of the files that you want to delete. Tap a file again if you want to de-select it.
3. Tap  to delete the selected files.

### VIEWING VIDEOS + PHOTOS ON YOUR PHONE

Connect your camera to the GoPro Quik app to see all of the media stored on your SD card, in the cloud, and in the app.

### VIEWING VIDEOS + PHOTOS ON A COMPUTER

To see your media on a computer, save the files to your computer using an SD card reader.

## Pairing to the Quik App + Other Devices

---

### BLUETOOTH® CONNECTIVITY

Your GoPro can be paired with a wide a variety of Bluetooth® devices to help you get the shot you want or enhance your recording. This can include the GoPro Quik app, GoPro remote controls, wireless external microphones, and wireless earbuds that let your GoPro hear your voice commands when it's mounted out of earshot.

Make sure that your device is in pairing mode, and then follow these steps on your GoPro:

1. Swipe down on the rear screen to access the Dashboard, and then swipe left to add devices.
2. Tap  Pair Device. You GoPro will automatically start searching for compatible devices.

*Heads Up:* Your GoPro's Wireless Connections must be on to pair devices. Follow these steps to turn them on if needed:

1. Swipe down on the rear screen to access the Dashboard.
2. Swipe left and tap Preferences > Wireless Connections > Connections.

### SETTING THE CONNECTION SPEED

Your GoPro is set to use the 5GHz Wi-Fi band (the fastest available) when connecting to other mobile devices.

Change the Wi-Fi band to 2.4GHz if your device or region does not support 5GHz.

1. Swipe down on the rear screen to access the Dashboard.
2. Swipe left and tap Preferences > Wireless Connections > Wi-Fi Band.

## Automatic Highlight Videos

---

**NOTE:** Cloud-based features including automatic highlight videos and Auto Upload are not available in China.

### HIGHLIGHT VIDEOS FROM YOUR SINGLE-LENS FOOTAGE

Have amazing highlight videos of your adventures created from your single-lens footage and sent to your phone automatically. Start by signing up for a GoPro Premium or Premium+ subscription and connecting your camera to your Wi-Fi network.

1. Subscribe to GoPro at [gopro.com/subscription](https://gopro.com/subscription).
2. Set up your GoPro to Auto Upload your footage to the cloud.
3. Follow the Quik app's on-screen instructions to complete the setup.

*Heads Up:* Be sure to allow notifications so that you'll know when a new highlight video is ready.

Once set up, simply plug in your GoPro to charge while it's connected to your home Wi-Fi network. While it's charging, your footage will be automatically uploaded to the cloud, where your single-lens footage will be used to create highlight videos complete with beat-synced music and effects. You'll get a notification on your phone letting you know when your video is ready to watch and share.

## 360 Editing With the Quik App

---

### REFRAMING

Editing 360 footage is called Reframing. You can use the GoPro Quik app to Reframe your 360 footage into shareable traditional videos, change perspectives, play with different capture angles, and more. The creative possibilities are endless.

Feature	Description
Object Tracking	Keeps the focus on your subject and follows it throughout your 360 footage.
POV Mode	Automatically plays back the action from your point of view.
MotionFrame	Makes editing your 360 videos as easy as moving your phone to find the best angles.
Keyframes	Select key moments and angles in your video and the Quik app will automatically create smooth transitions between them.
CameraFX	Add pro-level motion with effects like Spin, Flip, Roll, Wobble, Tiny Planet, and more.

## Using the Dashboard

---

With your camera in landscape orientation, swipe down on the rear screen to access the Dashboard.

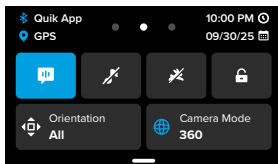

### DASHBOARD FEATURES

The Dashboard lets you quickly tap the following settings on and off:

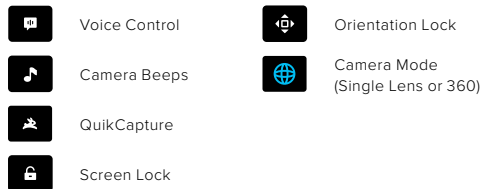

**PRO TIP:** Tap and hold the Voice Control and Camera Beeps icons to access and adjust their settings.

## Saving + Deleting Your Media

---

With your camera in landscape orientation, swipe down on the rear screen to access the Dashboard, and then swipe right to see your SD card status. From this screen you can manage SD card storage and set up cloud upload with a GoPro subscription.

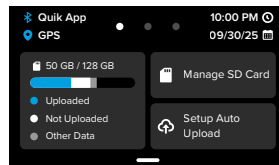

### SD CARD STORAGE

The tile on the left shows your SD card capacity, plus the amount of media on your SD card that has been uploaded and saved to the GoPro cloud.

### MANAGE SD CARD

Tap to delete media on your SD card. Options will vary based on whether or not your media has been uploaded and saved to the cloud.

### SET UP AUTO UPLOAD/START UPLOAD

Tap here to back up your media to the cloud with a GoPro subscription. Options will vary based on the upload status of your media.

## Saving + Deleting Your Media

---

### AUTO UPLOADING TO THE CLOUD

With a GoPro Premium or Premium+ subscription, you can automatically upload your media to the cloud where you can view, edit, and share it from any device.

1. Subscribe to GoPro at [gopro.com/subscribe](https://gopro.com/subscribe) or through the GoPro Quik app.
2. Connect your camera to the GoPro Quik app.
3. Tap  on your camera's SD card status screen or in the app.
4. Connect your camera to a power outlet. The upload will start automatically.

After first-time setup, your camera won't need to connect to the app to start Auto Upload.

### SWITCHING TO MANUAL CLOUD UPLOAD

You can also manually upload your media to the cloud at any time. (Your GoPro must be connected to a power outlet, and Auto Upload must be off.)

1. Connect your camera to a power outlet.
2. Swipe down to access the Dashboard.
3. Swipe right and tap Cloud Upload.

### ACCESSING YOUR CLOUD MEDIA

1. Open the GoPro Quik app on your device.
2. Tap  and select Cloud to view, edit, and share your content.

---

**PRO TIP:** Use your cloud media to create video edits with the GoPro Quik app without downloading it to your phone.

## Saving + Deleting Your Media

---

### TURNING OFF AUTO UPLOAD



You can keep your camera from trying to upload every time it's connected to a power outlet and fully charged.

1. Swipe down on the rear screen to access the Dashboard.
2. Swipe left and tap Preferences > Cloud Upload > Auto Upload.

### CONNECTING TO A DIFFERENT WIRELESS NETWORK

1. Connect your camera to the GoPro Quik app.
2. After connecting, tap Manage Auto Upload on the app.
3. Tap Wi-Fi Networks on the app.

### SAVING TO YOUR PHONE WIRELESSLY

1. Connect your camera to the GoPro Quik app.
2. Tap Download to download all of your new footage to the app.
3. Tap View Media  for a gallery view of all of your media. Tap to select individual files or use  to select multiple files and then tap download to save the selected files to the app.

### SAVING TO YOUR PHONE WITH A WIRED CONNECTION

1. Use the appropriate cable (not included) to connect your GoPro to your phone.
2. Start the GoPro Quik app on your phone and follow the on-screen instructions.

### SAVING TO A COMPUTER

Copy your media from your SD card to a computer using an SD card reader.

*Heads Up:* Low-resolution video (LRV) and thumbnail (THM) files are hidden from view. To access these files on a Mac®, open the folder with the video files and press Command + Shift + . (dot). From Windows® File Explorer, select View > Show > Hidden Items.

## Saving + Deleting Your Media



---

### AUTO CLEAR (DELETING MEDIA AUTOMATICALLY)

Your camera can be set to automatically delete all of the media from your camera's SD card once it has been safely uploaded to the cloud.

1. Swipe down on the rear screen to access the Dashboard.
2. Swipe left and tap Preferences > Setup Cloud Upload > Auto Clear.

### DELETING WITH THE GOPRO QUIK APP

1. Open the GoPro Quik app and tap  to access your GoPro.
2. Tap View Media to see the photos and videos on your SD card.
3. Tap  and then the thumbnails of the photos and videos you'd like to delete.
4. Tap  to delete the selected files.

---

**PRO TIP:** You can also tap  along the bottom navigation bar of the app to access a gallery view of all the media stored in the app, in the cloud, and on your phone.

### DELETE BY REFORMATTING YOUR SD CARD

Reformatting is the fastest way to delete all of the media on your SD card. This will erase all of your media, so be sure to save it first.

1. Swipe down on the screen to access the Dashboard.
2. Swipe left and tap Preferences > Reset > Format SD Card.
3. Tap Format to delete all files and reformat your card.

---

**PRO TIP:** Reformatting your SD card regularly will also help keep it in good condition.

## Setting Your Preferences

---

With your camera in landscape orientation, swipe down on the rear screen to access the Dashboard, and then swipe left to add devices and access preferences.

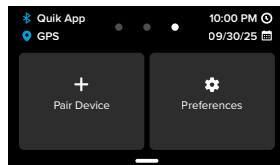

### PAIR DEVICES

Tap to pair new devices with your GoPro.

### PREFERENCES

Tap to set up your GoPro exactly the way you want it.

## Setting Your Preferences

---

### SET UP AUTO UPLOAD

Preference	Description
Auto Upload	Set up and turn on Auto Upload to the cloud with your GoPro subscription.
Start Upload	Lets you start uploading media to the cloud immediately.
Auto Clear	Automatically clears all media from your SD card after it's been uploaded to the cloud.

### WIRELESS CONNECTIONS

Preference	Description
Connections	Turn your camera's wireless connections on and off.
Wireless Info	See your camera's name and password.
Auto Wi-Fi Network	Keep your camera on as a wireless access point so you can quickly connect to third-party apps for 360 scans.
Wi-Fi Band	Choose 5GHz or 2.4GHz as your connection speed. Set 5GHz only if your phone and region support it.
Reset Connections	Clear all connections to your devices and reset your camera's password. This means you'll have to reconnect each device.

## Setting Your Preferences

---

### GENERAL

Preference	Description
Beep Volume	Choose High (default), Med, Low, or Mute. The volume you set here can be toggled on or off using the Dashboard.
QuikCapture Default	Choose the video mode your GoPro captures with when you use QuikCapture.
Default Preset	Set the preset your GoPro captures with when you turn it on using the Mode button  . This setting does not affect QuikCapture.
Auto Power Off	Choose 1, 5 (default), 15, or 30 Min, or Never.
LEDs	Set which camera LEDs you'd like to blink.
360 Photo Format	Choose whether to save your 360 videos as .36P files (default, compatible with GoPro apps for the better viewing and editing) or .JPG files (not compatible with GoPro apps).

### GPS

Preference	Description
GPS	Turn GPS on to tag your footage with location, speed, altitude, and more that you can include as optional data overlays in your footage.

## Setting Your Preferences

---

### VOICE CONTROL

Preference	Description
Voice Control	Turn Voice Control on and off. It can also be toggled on or off using the Dashboard.
Language	Choose your Voice Control language.
Commands	See a complete list of voice commands.

### DISPLAYS

Preference	Description
Screen Saver	Set the rear screen saver to 1, 2 (default), 3, or 5 minutes. Choose Never to leave your screen on. <i>Heads Up:</i> The camera buttons and Voice Control still work even when the screen is off.
Brightness	Use the slider to adjust your screen's brightness.
Grid	Use a grid on the rear touch screen to frame your shot.

## Setting Your Preferences

---

### REGIONAL

Preference	Description
Language	Choose the language that appears on the camera.
Regional Format	Choose the regional frame rate for recording and playback on a TV. The right format for your region will help prevent flicker on a TV/HDTV. 60Hz (NTSC) regions include North America, Japan, Taiwan, the Philippines, and parts of South America. 50Hz (PAL) regions include most of Europe and Africa, China, Australia, and India. Be sure to check your region to see which setting to use.

### DATE + TIME

Preference	Description
Date Format	This is set automatically based on the language that you chose at setup. You can also change it manually here.
Date	Use to manually adjust the date.
Time Zone	Set your camera's time zone.
Time	Use to manually adjust the time.

## Setting Your Preferences

---

Preference	Description
Daylight Savings Time	Turn daylight savings time on if you are in a region that is currently observing daylight savings time. Your camera's clock will set itself one hour ahead. Turn daylight savings time off when daylight savings time is over to return to standard time.

### ABOUT

Preference	Description
GoPro Updates	Update your camera's software to ensure you have the latest features and performance upgrades.
Camera Info	Find your camera's name and serial number, and see which software version your camera is using.
Battery Info	Check your battery's health.

### REGULATORY

Preference	Description
Regulatory	See your GoPro's certifications.

## Setting Your Preferences

---

### RESET

Preference	Description
Format SD Card	Reformat your SD card. This will erase all of your media, so be sure to save it first.
Reset Presets	Reset the preloaded presets to their original settings and delete all custom presets.
Reset Camera Tips	See all of the camera tips from the beginning.
Factory Reset	Restore all of your camera's settings and clear all connections.

## Mounting Your GoPro

---

### USING 1/4-20 MOUNTS

Your GoPro has 1/4-20 mounting threads that make it compatible with standard tripods and camera accessories, plus a wide range of GoPro mounts that were specially made to capture invisible 360 pole shots.

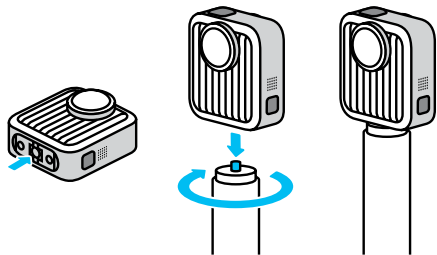

**WARNING:** Your GoPro could become loose or be dislodged when used with 1/4-20 mounts under extreme conditions. Use the mounting fingers for more secure mounting in extreme conditions.

---

## Mounting Your GoPro

---

### USING THE MOUNTING FINGERS

Depending on the mount you're using, you'll either use a mounting buckle or attach your GoPro directly to the mount itself.

1. Flip the folding fingers down into the mounting position.
2. Interlock the folding fingers on your camera with the mounting fingers on the buckle.
3. Secure your camera to the mounting buckle with a thumb screw.

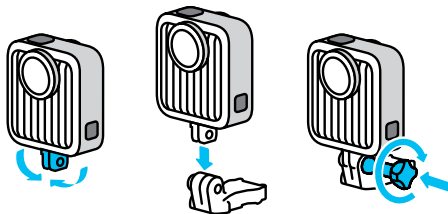

## Mounting Your GoPro

---

### ATTACHING THE MOUNTING BUCKLE TO THE MOUNT

1. Flip up the mounting buckle plug.
2. Slide the buckle into the mount until it clicks into place.
3. Press the plug back down so that it sits flush with the buckle.

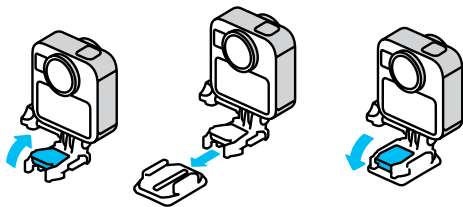

## Mounting Your GoPro

---

### MAGNETIC LATCH MOUNTS

Magnetic Latch Mounts (sold separately) are the easiest ways to mount your GoPro. Simply attach them to an extension pole, body mount, or other gear setup.

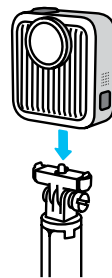

Powerful magnets help line up your GoPro so all you have to do is snap it in place. A squeeze of the auto-engage latches quickly detaches your GoPro, making it faster than ever to swap your camera between mounts. Available at [gopro.com](https://gopro.com).

## Mounting Your GoPro

---

### USING THE ADHESIVE MOUNTS

Follow these guidelines when attaching adhesive mounts to helmets, vehicles, and gear:

- Attach mounts at least 24 hours before you use them.
- Only attach the mounts to smooth surfaces. They won't stick properly to porous or textured surfaces.
- Firmly press mounts into place. Be sure the adhesive is in full contact with the surface.
- Only use on clean, dry surfaces. Wax, oil, dirt, or other debris will weaken the bond, and you could lose your camera.
- Attach mounts in dry, room-temperature conditions. They won't stick properly in cold or damp environments or on cold or damp surfaces.
- Check state and local regulations and laws to ensure that attaching a camera to equipment (such as hunting gear) is permitted. Always comply with regulations that restrict the use of consumer electronics or cameras.



**WARNING:** To avoid injury, do not use a tether when mounting your camera on a helmet. Do not mount the camera directly on skis or snowboards.

---

For more information about mounts, visit [gopro.com](http://gopro.com).

## Mounting Your GoPro

---

**WARNING:** Always use a helmet that meets applicable safety standards if you're using a GoPro helmet mount or strap.



Choose the right helmet for your sport or activity, and make sure that it's the right size and fit for you. Check to see that your helmet's in good condition, and always follow the manufacturer's instructions on safe use.

Replace any helmet that's been subjected to a major impact. No helmet can protect against injury in every accident. Be safe.

---

## Replacing the Lenses

---

The MAX2 lenses are designed to be replaced if they're scratched or damaged. Simply swap in a new replacement lens instead of replacing your entire camera.

The replacement kit includes 2 lenses, a microfiber cleaning cloth, and an easy-to-use tool that lets you quickly swap out lenses on the go. Available at [gopro.com](https://gopro.com).

---

**PRO TIP:** Be sure to use authentic GoPro MAX2 Replacement Lenses to ensure a proper fit.

**NOTE:** Only remove your camera's lens in a dry, dust-free environment when you're ready to replace the lens. The camera is not waterproof when the lens has been removed.

## Removing the Door

---

There might be times when you need to remove your camera's door.

**NOTE:** Only remove the door in a dry, dust-free environment. The camera is not waterproof when the door is open or removed.

### REMOVING THE DOOR

1. Unlock the latch, and then flip the door open.
2. With the door in a horizontal position, gently pull outward until it snaps off.

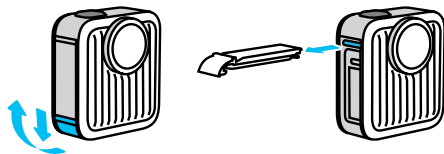

**WARNING:** Avoid using your GoPro with the door off. The battery could slide out during use.

---

## Removing the Door

---

### REATTACHING THE DOOR

1. Line the door up with the small silver bar.
2. Press the door tightly into the small silver bar until it snaps into place and is securely attached.



**WARNING:** Your camera's door is removable. Be sure that the door is securely locked and sealed after closing.

---

## Maintenance

---

Follow these tips to get the best performance from your camera:

- The lenses are made to be extremely tough, but can still be scratched or cracked. Keep them clean with a soft, lint-free cloth.
- Your GoPro is waterproof to 16ft (5m) to protect against splashes and drops in the water. Be sure the door is closed before using it in or around water, dirt, or sand.
- Before closing the door, be sure the seal is free of debris. Use a cloth to clean the seal if needed.
- Make sure your GoPro is dry and clean before opening the door. Rinse your camera with fresh water and dry it with a cloth if needed.
- If sand or debris hardens around the door, soak your camera in warm tap water for 15 minutes and then rinse thoroughly to remove the debris. Make sure your camera is dry before opening the door.
- For the best audio performance, shake your camera or blow on the mic to remove water and debris from the microphone holes. Do not use compressed air to blow into the mic holes. This could damage the internal waterproof membranes.
- After every use in salt water, rinse your camera with fresh water, and dry it with a soft cloth.
- If debris gets stuck between the lens and trim ring, flush it out with water or air. Do not insert foreign objects around the lens.

## Battery Information

---

### MAXIMIZING BATTERY LIFE

Here are some things you can do to maximize battery life:

- Capture video at lower frame rates and resolutions.
- Use the Screensaver and lower the screen Brightness.
- Turn off Wireless Connections.
- Record with QuikCapture and set up Auto Power Off.

### RECORDING WHEN PLUGGED INTO A POWER SOURCE

You can use the USB-C cable that came with your camera to shoot videos and photos while your camera is plugged in to a power source. This is perfect for capturing long videos and time lapse events.

Be careful not to touch the area near the SD card slot when recording. Disturbing the SD card could interrupt or stop the recording. Your content will not be damaged or lost as a result of this disturbance, but you may need to restart your camera to continue.

Even though your camera is charging, the battery will not charge during recording. It will start charging when you stop recording.

*Heads Up:* Because the door is open, your camera is not waterproof when charging.

---

**PRO TIP:** Use the USB Pass-Through Door (sold separately) to keep your camera weather resistant and the battery in place when plugged into an external power source.



**WARNING:** Only use an agency-approved power supply which meets local regulatory requirements (e.g. UL, CSA, VDE, CCC) to charge your GoPro. Using non-compliant power adapters and cables could damage your camera battery and could lead to fire or leakage.

## Battery Information

---

### BATTERY STORAGE + HANDLING

Your GoPro is full of sensitive components, including the battery. Avoid exposing your camera to very hot or cold temperatures. Extreme temperatures may temporarily shorten battery life or cause your camera to temporarily stop working properly. Avoid dramatic temperature or humidity changes as condensation may form on or within the camera.

Do not dry your camera with an external heat source such as a microwave oven or hair dryer. Damage to the camera or battery caused by contact with liquid inside the camera is not covered under the warranty.

Do not store your battery with metal objects like coins, keys, or necklaces. If the battery terminals come in contact with metal objects, this may cause a fire.

Do not make any unauthorized alterations to your camera. Doing so may compromise safety, regulatory compliance, and performance, and may void the warranty.

*Heads Up:* Batteries have reduced capacity in cold weather. This affects older batteries even more. If you regularly capture at low temperatures, replace batteries yearly for optimal performance.

---

**PRO TIP:** Fully charge your camera before storing it away to help maximize battery life.

## Battery Information

---



**WARNING:** Do not drop, disassemble, open, crush, bend, deform, puncture, shred, microwave, incinerate, or paint your camera or battery. Do not insert foreign objects into any opening on the camera, such as the USB-C port. Do not use your camera if it's been damaged—for example, if cracked, punctured, or harmed by water. Disassembling or puncturing the integrated battery can cause an explosion or fire.

### BATTERY DISPOSAL

Most rechargeable lithium-ion batteries are classified as non-hazardous waste and are safe for disposal in the normal municipal waste stream. Many regions require battery recycling. Check your local laws to make sure that you can dispose of rechargeable batteries in your regular trash. To safely dispose of lithium-ion batteries, protect terminals from exposure to other metal with packing, masking, or electrical tape so they do not cause a fire while being transported.

Lithium-ion batteries, however, do contain recyclable materials and are accepted for recycling by the Rechargeable Battery Recycling Corporation's (RBRC) Battery Recycling Program. We encourage you to visit Call2Recycle at [call2recycle.org](http://call2recycle.org) or call 1-800-BATTERY in North America to find a convenient recycling location.

Never dispose of a battery in a fire because it may explode.



**WARNING:** Only use GoPro replacement batteries, power cables, and battery charging accessories or devices with your camera.

Using an older GoPro battery or non-GoPro battery could greatly limit your camera's performance, will void your warranty, and may cause fire, electric shock, or other safety risk.

## Camera Alerts

---

Problems are rare, but your GoPro will let you know if anything comes up. Here are some of the messages you might see.

Message	Description
Camera Is Too Hot	Your camera's normal operating temperature range is 14°F ~ 95°F (-10°C ~ 35°C). It will shut down if it gets too hot. Let it cool before using it again.
SD Card Error	There's a problem with your SD card. Restart your camera. It will try to repair damaged files and restore your camera back to full function.
Repairing Your File	Usually caused when your camera loses power while recording or if there's a problem saving the file. Your GoPro will let you know when a repair is in progress and if the file was fixed.
SD Card Rating	Your camera will let you know if your SD card is rated below the required A2 and V30 speed rating or has degraded over time and can no longer perform up to its standards.
Battery Low, Powering Off	Appears when the battery charge drops below 10%. If the charge runs out while recording, your camera will stop recording, save the video, and turn itself off.

## Resetting Your Camera

---

### RESTARTING YOUR GOPRO

If your camera is not responding, press and hold the Mode button  for 10 seconds. This will restart your camera. There will be no changes to your settings.

### RESTORE PRESETS TO THE DEFAULTS

This will reset all of your camera's original preset settings to the defaults.

1. Swipe down on the rear screen to access the Dashboard.
2. Swipe left and tap Preferences > Reset > Reset Presets.

*Heads Up:* Restoring your camera's original preset settings to their defaults will delete your custom presets.

### RESETTING CONNECTIONS

This will clear your device connections and reset your camera's password. Resetting connections means you'll have to reconnect all of your devices.

1. Swipe down on the rear screen to access the Dashboard.
2. Swipe left and tap Connections > Reset Connections.

### RESETTING THE CAMERA TIPS

Want to see the camera tips again? Here's how to see them all from the beginning.

1. Swipe down on the rear screen to access the Dashboard.
2. Swipe left and tap Preferences > Reset > Reset Camera Tips.

## Resetting Your Camera

---

### RESTORING FACTORY SETTINGS

This will restore all of your camera's original settings, clear all device connections, and deregister your camera from your GoPro subscription.

This is useful if you're giving your camera to a friend and want to completely reset it to its original state.

1. Swipe down on the rear screen to access the Dashboard.
2. Swipe left and tap Preferences > Reset > Factory Reset.

*Heads Up:* Restoring the factory settings will not delete any content from your SD card or have any effect on your camera's software.

## Troubleshooting

---

### MY GOPRO WON'T POWER ON

Make sure your GoPro is charged. If charging the battery doesn't work, try restarting your camera.

### MY GOPRO WON'T RESPOND WHEN I PRESS A BUTTON

Restart your camera by pressing and holding the Mode button  for 10 seconds.

### PLAYBACK ON MY COMPUTER IS CHOPPY

Choppy playback is usually not a problem with the file. If your footage skips, one of these issues is probably the cause:

- The computer doesn't work with HEVC files. Try downloading the latest version of the GoPro Player for Mac® or Windows® for free at [gopro.com/apps](https://gopro.com/apps).
- Your computer doesn't meet the minimum requirements of the software you're using for playback.

### I FORGOT MY CAMERA'S USERNAME OR PASSWORD

Swipe down on the rear screen to access the Dashboard, swipe left, and then tap Preferences > Connections > Camera Info.

### I DON'T KNOW WHICH SOFTWARE VERSION I HAVE

Swipe down on the rear screen to access the Dashboard, swipe left, and then tap Preferences > About > Camera Info.

### I CAN'T FIND MY CAMERA'S SERIAL NUMBER

The serial number is stamped inside the battery compartment of your camera. You can also find it by swiping down on the rear screen to access the Dashboard, swiping left, and then tapping Preferences > About > Camera Info.

For more answers to commonly asked questions, see [gopro.com/help](https://gopro.com/help).

## Customer Support

---

GoPro is dedicated to providing the best possible service. To reach GoPro Customer Support, visit [gopro.com/help](https://gopro.com/help).

## Trademarks

---

GoPro, Single Lens, and their respective logos are trademarks or registered trademarks of GoPro, Inc. in the United States and other countries. The Bluetooth word mark and logos are registered trademarks owned by Bluetooth SIG, Inc., and any use of such marks is under license. All other trademarks are the property of their respective owners. © 2025 GoPro, Inc. All rights reserved. For patent information, visit [gopro.com/patents](https://gopro.com/patents). GoPro, Inc., 3025 Clearview Way, San Mateo CA 94402 | GoPro GmbH, Baierbrunner Str. 15 Bldg. D, 81379 Munich, Germany

## Regulatory Information

---

Your GoPro will transmit data using HTTP, HTTPS protocols when connected to the GoPro Quik app and auto uploading to the cloud.

To see the complete list of country certifications, refer to the Important Product + Safety Instructions included with your camera or visit [gopro.com/help](https://gopro.com/help).

